

Cylinder Magnetic Separator

Cylinder Magnetic Separator – SCXL Series used in flow tube

Available for powdery and flaky material, such as flour and bran
Easy-cleaning structure to wipe off Fe particles conveniently and efficiently.

Technical data

Magnetic performance: 9'000Gs-12'000Gs
Materials of housing and other parts: 304 stainless steel/316 stainless steel
Surface finish: Sand blasting/Powder painting

PATENTED PRODUCT
ZL 2011 1 0319437.8



Model No.	Inlet	Height
	Φ A mm	B mm
SCXL1515	150	210
SCXL1818	180	210
SCXL2020	200	210

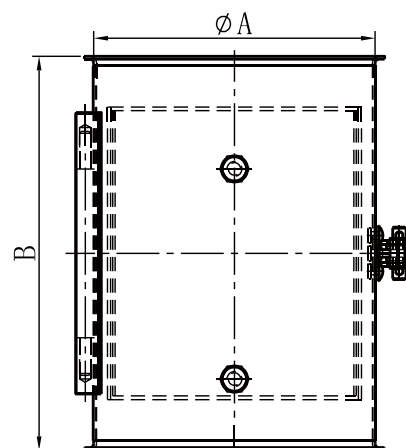

Beijing OeMag International Co., Ltd

Tel: +86-10-67609550; Fax: +86-10-67609565; E-mail: oeomag@oeomag.com

Cylinder Magnetic Separator

Positive pressure conveying

Available for powdery and flaky material, such as flour and bran
Easy-cleaning structure to wipe off Fe particles conveniently and efficiently
Available for positive pressure conveying

Technical data

Magnetic performance: 10'000Gs
Materials of housing and other parts: 304 stainless steel/316 stainless steel
Surface finish: Sand blasting/Powder painting



Model No.	Capacity(t/h)	Inlet		
		Φ A mm	Φ B mm	C mm
SCXL1516H	11	150	150	210
SCXL1818H	16	180	180	210
SCXL2020H	20	200	200	210

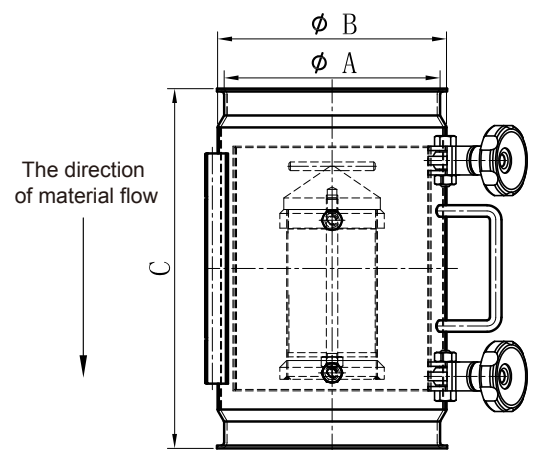

Beijing OeMag International Co., Ltd

Tel: +86-10-67609550; Fax: +86-10-67609565; E-mail: oeMag@oemag.com

Cylinder Magnetic Separator

Negative pressure conveying

Available for powdery and flaky material, such as flour and bran
Easy-cleaning structure to wipe off Fe particles conveniently and efficiently
Available for negative pressure conveying

Technical data

Magnetic performance: 10'000Gs
Materials of housing and other parts: 304 stainless steel/316 stainless steel
Surface finish: Sand blasting/Powder painting



Model No.	Capacity(t/h)	Inlet	Dimension	
		Φ A mm	Φ B mm	C mm
SCXL1516G	11	150	150	210
SCXL1818G	16	180	180	210
SCXL2020G	20	200	200	210

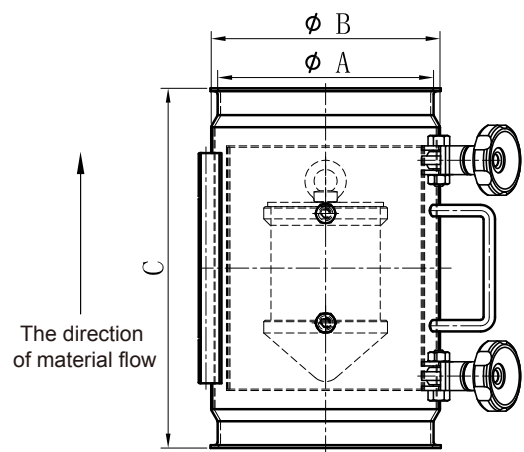

Beijing OeMag International Co., Ltd

Tel: +86-10-67609550; Fax: +86-10-67609565; E-mail: oeomag@oeomag.com